

Instructions for Use

Interleukin 6 (human) ELISA

RUO

REF EIA-5612



96



DRG Instruments GmbH, Germany
Frauenbergstraße. 18, 35039 Marburg
Phone: +49 (0)6421-1700 0, Fax: +49 (0)6421-1700 50
Website: www.drg-diagnostics.de
E-mail: drg@drg-diagnostics.de

Distributed by:



DRG International, Inc., USA
841 Mountain Ave., Springfield, NJ 07081
Phone: (973) 564-7555, Fax: (973) 564-7556
Website: www.drg-international.com
E-mail: corp@drg-international.com

**Please use only the valid version of the Instructions for Use provided with the kit.
Verwenden Sie nur die jeweils gültige, im Testkit enthaltene, Gebrauchsanweisung.
Si prega di usare la versione valida delle istruzioni per l'uso a disposizione con il kit.
Por favor, se usa solo la version valida de la metodico técnico incluido aqui en el kit.
Utilisez seulement la version valide des Instructions d'utilisation fournies avec le kit.**

Table of Contents / Inhaltsverzeichnis

1	INTENDED USE.....	2
2	SUMMARY.....	2
3	PRINCIPLES OF THE TEST.....	3
4	REAGENTS PROVIDED.....	3
5	STORAGE INSTRUCTIONS – ELISA KIT.....	3
6	SPECIMEN COLLECTION AND STORAGE INSTRUCTIONS.....	4
7	MATERIALS REQUIRED BUT NOT PROVIDED.....	4
8	PRECAUTIONS FOR USE.....	4
9	PREPARATION OF REAGENTS.....	5
10	TEST PROTOCOL.....	7
11	CALCULATION OF RESULTS.....	9
12	LIMITATIONS.....	10
13	PERFORMANCE CHARACTERISTICS.....	11
14	REAGENT PREPARATION SUMMARY.....	13
15	TEST PROTOCOL SUMMARY.....	14
1	MITGELIEFERTE REAGENZIEN.....	15
2	LAGERHINWEISE.....	15
3	SICHERHEITSVORKEHRUNGEN FÜR DEN GEBRAUCH.....	15
4	VORBEREITUNG DER REAGENZIEN.....	16
5	TESTPROTOKOLL.....	18
	SYMBOLS USED.....	20

1 INTENDED USE

The Interleukin 6 (human) ELISA is an enzyme-linked immunosorbent assay for the quantitative detection of human IL-6. **The Interleukin 6 (human) ELISA is for research use only. Not for diagnostic or therapeutic procedures.**

2 SUMMARY

Interleukin-6 (IL-6) is a multi-functional cytokine that regulates immune responses, acute phase reactions and hematopoiesis and may play a central role in host defense mechanisms. The gene for human IL-6 has been localized to chromosome 7p21. The genomic sequence has been determined. IL-6 is usually not produced constitutively by normal cells, but its expression is readily induced by a variety of cytokines, lipopolysaccharide or viral infections. The IL-6 gene product is a single chain protein with a molecular mass ranging from 21 to 28 kDa, depending on the cellular source. Extensive posttranslational modifications like N- and O-linked glycosylation as well as phosphorylation seem to account for this heterogeneity. The cDNA for IL-6 predicts a precursor protein of 212 amino acids.

IL-6 is a pleiotropic cytokine produced by a variety of cells. It acts on a wide range of tissues, exerting growth-induction, growth-inhibition, and differentiation respectively, depending on the nature of the target cells.

IL-6 is involved in

- the induction of B-cell differentiation,
- the induction of acute phase proteins in liver cells,
- growth promotion of myeloma/plasmacytoma/hybridoma cells,
- induction of IL-2 and IL-2 receptor expression,
- proliferation and differentiation of T cells,
- inhibition of cell growth of certain myeloid leukemic cell lines and induction of their differentiation to macrophages,
- enhancement of IL-3-induced multipotential colony cell formation in hematopoietic stem cells and induction of maturation of megakaryocytes as a thrombopoietic factor,
- induction of mesangial cell growth,
- induction of neural differentiation of PC 12 cells and
- induction of keratinocyte growth.

The abnormal production of IL-6 was first suggested to be related to polyclonal B-cell activation with autoantibody production in patients with cardiac myxoma. Since then, IL-6 has been suggested to be involved in the pathogenesis of a variety of diseases. Measurement of IL-6 levels in serum and other body fluids thus provides more detailed insights into various pathological situations.

Infections:

Body fluids of patients with acute local bacterial or viral infections and serum of patients with gram-negative or positive bacteremia contain elevated levels of biologically active IL-6.

Obstetric Infections:

IL-6 has emerged as a reporter cytokine for intraamniotic infection.

Diseases associated with an altered immune system (polyclonal B-cell abnormalities or autoimmune diseases):

Elevated levels of circulating IL-6 have been detected in patients with cardiac myxoma, Castleman's disease, rheumatoid arthritis, IgM gammopathy and in those with acquired immunodeficiency syndrome as well as alcoholic liver cirrhosis.

Proliferative diseases:

Elevated plasma levels of IL-6 are observed in patients with psoriasis and mesangial proliferative glomerulonephritis.

Neoplastic Diseases:

Increased systemic levels of IL-6 have been detected in patients with multiple myeloma, other B-cell dyscrasias, Lennert's T lymphoma, Castleman's disease, renal cell carcinoma and various other solid tumors.

Inflammatory responses:

IL-6 is involved in the induction of acute phase proteins and induction of fever. Elevated serum levels of IL-6 are also found in patients with severe burns, in serum and plasma as a marker for predicting postoperative complications, in serum and urine of recipients of kidney transplants before rejection, in the serum of septic shock patients and in patients with inflammatory arthritis and traumatic arthritis.

For literature update please contact drg@dr-gdiagnostics.de.

3 PRINCIPLES OF THE TEST

An anti-human IL-6 coating antibody is adsorbed onto microwells.

Human IL-6 present in the sample or standard binds to antibodies adsorbed to the microwells. A biotin-conjugated anti-human IL-6 antibody is added and binds to human IL-6 captured by the first antibody.

Following incubation unbound biotin-conjugated anti-human IL-6 antibody is removed during a wash step. Streptavidin-HRP is added and binds to the biotin-conjugated anti-human IL-6 antibody.

Following incubation unbound Streptavidin-HRP is removed during a wash step, and substrate solution reactive with HRP is added to the wells.

A coloured product is formed in proportion to the amount of human IL-6 present in the sample or standard. The reaction is terminated by addition of acid and absorbance is measured at 450 nm. A standard curve is prepared from 7 human IL-6 standard dilutions and human IL-6 sample concentration determined.

4 REAGENTS PROVIDED

Reagents for Human IL-6 ELISA (96 tests)

- 1 aluminium pouch with a **Microwell Plate coated** with monoclonal antibody to human IL-6
- 1 vial (70 µL) **Biotin-Conjugate** anti-human IL-6 monoclonal antibody
- 1 vial (150 µL) **Streptavidin-HRP**
- 2 vials human IL-6 **Standard**, lyophilized, 200 pg/mL upon reconstitution
- 1 vial **Control high**
- 1 vial **Control low**
- 1 vial (5 mL) **Assay Buffer Concentrate 20x**
(PBS with 1% Tween 20, 10% BSA)
- 1 bottle (50 mL) **Wash Buffer Concentrate 20x**
(PBS with 1% Tween 20)
- 1 vial (15 mL) **Substrate Solution** (tetramethyl-benzidine)
- 1 vial (15 mL) **Stop Solution** (1M Phosphoric acid)
- 4 **Adhesive Films**

5 STORAGE INSTRUCTIONS – ELISA KIT

Store kit reagents between 2 °C and 8 °C, except controls. Store lyophilized controls at -20 °C.

Immediately after use remaining reagents should be returned to cold storage (2 °C to 8 °C), controls to -20 °C, respectively. Expiry of the kit and reagents is stated on labels.

Expiry of the kit components can only be guaranteed if the components are stored properly, and if, in case of repeated use of one component, this reagent is not contaminated by the first handling.

6 SPECIMEN COLLECTION AND STORAGE INSTRUCTIONS

Cell culture supernatant, serum and plasma (EDTA, citrate, heparin) were tested with this assay. Other body fluids might be suitable for use in the assay. Remove serum from the clot as soon as possible after clotting.

Samples containing a visible precipitate must be clarified prior to use in the assay.

Do not use grossly hemolyzed or lipemic specimens.

Samples should be aliquoted and must be stored frozen at -20 °C to avoid loss of bioactive human IL-6. If samples are to be run within 24 hours, they may be stored at 2 °C to 8 °C (for sample stability refer to 13.5).

Avoid repeated freeze-thaw cycles. Prior to assay, the frozen sample should be brought to room temperature slowly and mixed gently.

7 MATERIALS REQUIRED BUT NOT PROVIDED

- 5 mL and 10 mL graduated pipettes
- 5 µL to 1000 µL adjustable single channel micropipettes with disposable tips
- 50 µL to 300 µL adjustable multichannel micropipette with disposable tips
- Multichannel micropipette reservoir
- Beakers, flasks, cylinders necessary for preparation of reagents
- Device for delivery of wash solution (multichannel wash bottle or automatic wash system)
- Microwell strip reader capable of reading at 450 nm (620 nm as optional reference wave length)
- Glass-distilled or deionized water
- Statistical calculator with program to perform regression analysis

8 PRECAUTIONS FOR USE

- All chemicals should be considered as potentially hazardous. We therefore recommend that this product is handled only by those persons who have been trained in laboratory techniques and that it is used in accordance with the principles of good laboratory practice. Wear suitable protective clothing such as laboratory overalls, safety glasses and gloves. Care should be taken to avoid contact with skin or eyes. In the case of contact with skin or eyes wash immediately with water. See material safety data sheet(s) and/or safety statement(s) for specific advice.
- Reagents are intended for **research use only** and are not for use in diagnostic or therapeutic procedures.
- Do not mix or substitute reagents with those from other lots or other sources.
- Do not use kit reagents beyond expiration date on label.
- Do not expose kit reagents to strong light during storage or incubation.
- Do not pipette by mouth.
- Do not eat or smoke in areas where kit reagents or samples are handled.
- Avoid contact of skin or mucous membranes with kit reagents or specimens.
- Rubber or disposable latex gloves should be worn while handling kit reagents or specimens.
- Avoid contact of substrate solution with oxidizing agents and metal.
- Avoid splashing or generation of aerosols.
- In order to avoid microbial contamination or cross-contamination of reagents or specimens which may invalidate the test use disposable pipette tips and/or pipettes.
- Use clean, dedicated reagent trays for dispensing the conjugate and substrate reagent.
- Exposure to acid inactivates the conjugate.
- Glass-distilled water or deionized water must be used for reagent preparation.
- Substrate solution must be at room temperature prior to use.
- Decontaminate and dispose specimens and all potentially contaminated materials as they could contain infectious agents. The preferred method of decontamination is autoclaving for a minimum of 1 hour at 121.5 °C.
- Liquid wastes not containing acid and neutralized waste may be mixed with sodium hypochlorite in volumes such that the final mixture contains 1.0% sodium hypochlorite. Allow 30 minutes for effective decontamination. Liquid waste containing acid must be neutralized prior to the addition of sodium hypochlorite.

9 PREPARATION OF REAGENTS

Buffer concentrates should be brought to room temperature and should be diluted before starting the test procedure. If crystals have formed in the **Buffer Concentrates**, warm them gently until they have completely dissolved.

9.1 Wash Buffer (1x)

Pour entire contents (50 mL) of the **Wash Buffer Concentrate** (20x) into a clean 1000 mL graduated cylinder. Bring to final volume of 1000 mL with glass-distilled or deionized water. Mix gently to avoid foaming.

Transfer to a clean wash bottle and store at 2 °C to 25 °C. Please note that Wash Buffer (1x) is stable for 30 days.

Wash Buffer (1x) may also be prepared as needed according to the following table:

Number of Strips	Wash Buffer Concentrate (20x) (mL)	Distilled Water (mL)
1 - 6	25	475
1 - 12	50	950

9.2 Assay Buffer (1x)

Pour the entire contents (5 mL) of the **Assay Buffer Concentrate** (20x) into a clean 100 mL graduated cylinder. Bring to final volume of 100 mL with distilled water. Mix gently to avoid foaming.

Store at 2 °C to 8 °C. Please note that the Assay Buffer (1x) is stable for 30 days.

Assay Buffer (1x) may also be prepared as needed according to the following table:

Number of Strips	Assay Buffer Concentrate (20x) (mL)	Distilled Water (mL)
1 - 6	2.5	47.5
1 - 12	5.0	95.0

9.3 Biotin-Conjugate

Please note that the Biotin-Conjugate should be used within 30 minutes after dilution.

Make a 1:100 dilution of the concentrated **Biotin-Conjugate** solution with Assay Buffer (1x) in a clean plastic tube as needed according to the following table:

Number of Strips	Biotin-Conjugate (mL)	Assay Buffer (1x) (mL)
1 - 6	0.03	2.97
1 - 12	0.06	5.94

9.4 Streptavidin-HRP

Please note that the Streptavidin-HRP should be used within 30 minutes after dilution.

Make a 1:200 dilution of the concentrated **Streptavidin-HRP** solution with Assay Buffer (1x) in a clean plastic tube as needed according to the following table:

Number of Strips	Streptavidin-HRP (mL)	Assay Buffer (1x) (mL)
1 - 6	0.03	5.97
1 - 12	0.06	11.94

9.5 Human IL-6 Standard

Reconstitute **human IL-6 Standard** by addition of distilled water.

Reconstitution volume is stated on the label of the standard vial. Swirl or mix gently to insure complete and homogeneous solubilisation (concentration of reconstituted standard = 200 pg/mL).

Allow the standard to reconstitute for 10-30 minutes. Mix well prior to making dilutions.

After usage remaining standard cannot be stored and has to be discarded.

Standard dilutions can be prepared directly on the microwell plate (see 10.c) or alternatively in tubes (see 9.5.1).

9.5.1 External Standard Dilution

Label 7 tubes, one for each standard point.

S1, S2, S3, S4, S5, S6, S7

Then prepare 1:2 serial dilutions for the standard curve as follows:

Pipette 225 μ L of Assay Buffer (1x) into each tube.

Pipette 225 μ L of reconstituted standard (concentration = 200 pg/mL) into the first tube, labelled S1, and mix (concentration of Standard 1 = 100 pg/mL).

Pipette 225 μ L of this dilution into the second tube, labelled S2, and mix thoroughly before the next transfer.

Repeat serial dilutions 5 more times thus creating the points of the standard curve (see figure 1).

Assay Buffer (1x) serves as blank.

Figure 1

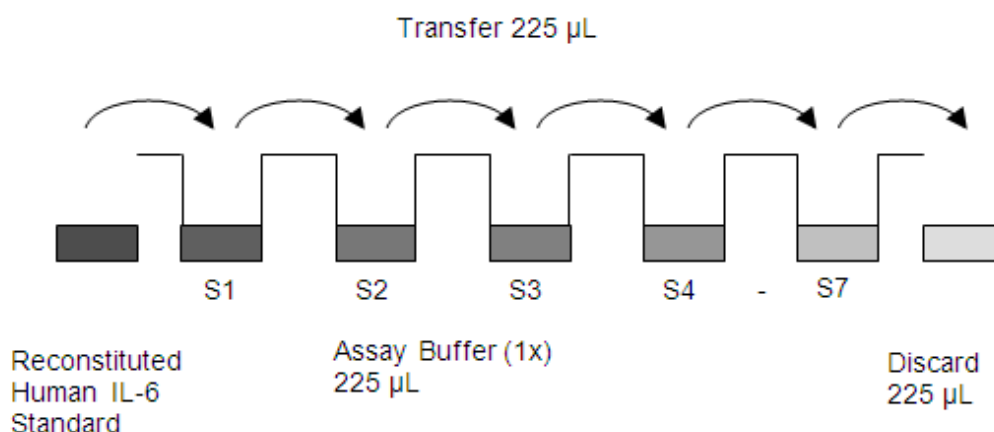

9.6 Controls

Reconstitute by adding 300 μ L distilled water to lyophilized **controls** (10-30 minutes). Swirl or mix gently to ensure complete and homogeneous solubilisation.

Further treat the controls like your samples in the assay.

For control range please refer to certificate of analysis or vial label.

Store reconstituted controls aliquoted at -20 $^{\circ}$ C. Avoid repeated freeze and thaw cycles.

10 TEST PROTOCOL

- a. Determine the number of microwell strips required to test the desired number of samples plus appropriate number of wells needed for running blanks and standards. Each sample, standard, blank and optional control sample should be assayed in duplicate. Remove extra microwell strips from holder and store in foil bag with the desiccant provided at 2 °C - 8 °C sealed tightly.
- b. Wash the microwell strips twice with approximately 400 µL Wash Buffer per well with thorough aspiration of microwell contents between washes. Allow the Wash Buffer to sit in the wells for about **10 – 15 seconds** before aspiration. Take care not to scratch the surface of the microwells. After the last wash step, empty wells and tap microwell strips on absorbent pad or paper towel to remove excess Wash Buffer. Use the microwell strips immediately after washing. Alternatively microwell strips can be placed upside down on a wet absorbent paper for not longer than 15 minutes. **Do not allow wells to dry.**
- c. **Standard dilution on the microwell plate** (Alternatively the standard dilution can be prepared in tubes - see 9.5.1): Add 100 µL of Assay Buffer (1x) in duplicate to all **standard wells**. Pipette 100 µL of prepared **standard** (see Preparation of Standard 9.5, concentration = 200.00 pg/mL), in duplicate, into well A1 and A2 (see Table 1). Mix the contents of wells A1 and A2 by repeated aspiration and ejection (concentration of standard 1 S1 = 100.00 pg/mL), and transfer 100 µL to wells B1 and B2, respectively (see Figure 2). Take care not to scratch the inner surface of the microwells. Continue this procedure 5 times, creating two rows of human IL-6 standard dilutions, ranging from 100.00 to 1.56 pg/mL. Discard 100 µL of the contents from the last microwells (G1, G2) used.

Figure 2

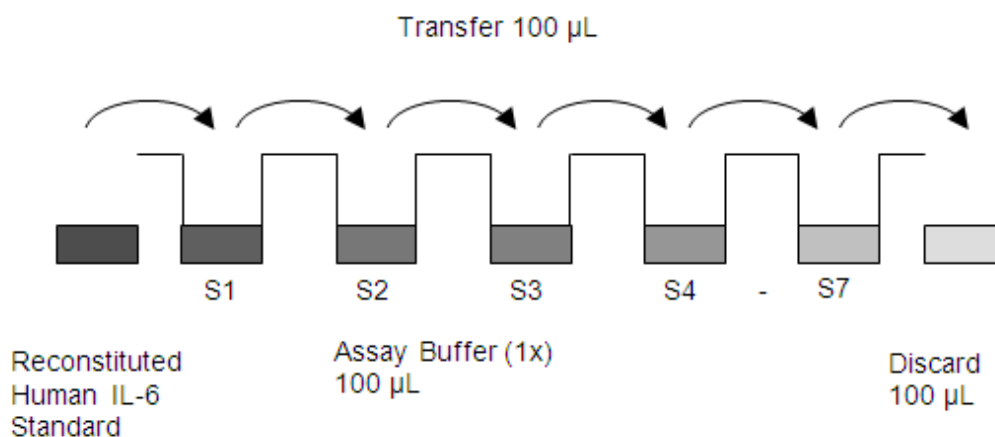

In case of an **external standard dilution** (see 9.5.1), pipette 100 µL of these standard dilutions (S1 to S7) in the standard wells according to Table 1.

Table 1

Table depicting an example of the arrangement of blanks, standards and samples in the microwell strips:

	1	2	3	4
A	Standard 1 (100.00 pg/mL)	Standard 1 (100.00 pg/mL)	Sample 1	Sample 1
B	Standard 2 (50.00 pg/mL)	Standard 2 (50.00 pg/mL)	Sample 2	Sample 2
C	Standard 3 (25.00 pg/mL)	Standard 3 (25.00 pg/mL)	Sample 3	Sample 3
D	Standard 4 (12.50 pg/mL)	Standard 4 (12.50 pg/mL)	Sample 4	Sample 4
E	Standard 5 (6.25 pg/mL)	Standard 5 (6.25 pg/mL)	Sample 5	Sample 5
F	Standard 6 (3.13 pg/mL)	Standard 6 (3.13 pg/mL)	Sample 6	Sample 6
G	Standard 7 (1.56 pg/mL)	Standard 7 (1.56 pg/mL)	Sample 7	Sample 7
H	Blank	Blank	Sample 8	Sample 8

- d. Add 100 µL of **Assay Buffer (1x)** in duplicate to the **blank wells**.
- e. Add 50 µL of **Assay Buffer (1x)** to the **sample wells**.
- f. Add 50 µL of each **sample** in duplicate to the **sample wells**.

-
- g. Prepare **Biotin-Conjugate** (see Preparation of Biotin-Conjugate 9.3).
 - h. Add 50 µL of **Biotin-Conjugate** to all wells.
 - i. Cover with an adhesive film and incubate at room temperature (18 °C to 25 °C) for 2 hours, if available on a microplate shaker set at 400 rpm.
 - j. Prepare **Streptavidin-HRP** (refer to Preparation of Streptavidin-HRP 9.4).
 - k. Remove adhesive film and empty wells. Wash microwell strips 4 times according to point b. of the test protocol. Proceed immediately to the next step.
 - l. Add 100 µL of diluted **Streptavidin-HRP** to all wells, including the blank wells.
 - m. Cover with an adhesive film and incubate at room temperature (18 °C to 25 °C) for 1 hour, if available on a microplate shaker set at 400 rpm.
 - n. Remove adhesive film and empty wells. Wash microwell strips 4 times according to point b. of the test protocol. Proceed immediately to the next step.
 - o. Pipette 100 µL of **TMB Substrate Solution** to all wells.
 - p. Incubate the microwell strips at room temperature (18 °C to 25 °C) for about 10 min. Avoid direct exposure to intense light.

The colour development on the plate should be monitored and the substrate reaction stopped (see next point of this protocol) before positive wells are no longer properly recordable. Determination of the ideal time period for colour development has to be done individually for each assay.

It is recommended to add the stop solution when the highest standard has developed a dark blue colour. Alternatively the colour development can be monitored by the ELISA reader at 620 nm. The substrate reaction should be stopped as soon as Standard 1 has reached an OD of 0.9 – 0.95.

- q. Stop the enzyme reaction by quickly pipetting 100 µL of **Stop Solution** into each well. It is important that the Stop Solution is spread quickly and uniformly throughout the microwells to completely inactivate the enzyme. Results must be read immediately after the Stop Solution is added or within one hour if the microwell strips are stored at 2 °C - 8 °C in the dark.
- r. Read absorbance of each microwell on a spectro-photometer using 450 nm as the primary wave length (optionally 620 nm as the reference wave length; 610 nm to 650 nm is acceptable). Blank the plate reader according to the manufacturer's instructions by using the blank wells. Determine the absorbance of both the samples and the standards.

Note:
In case of incubation without shaking the obtained O.D. values may be lower than indicated below. Nevertheless the results are still valid.

11 CALCULATION OF RESULTS

- Calculate the average absorbance values for each set of duplicate standards and samples. Duplicates should be within 20 per cent of the mean value.
- Create a standard curve by plotting the mean absorbance for each standard concentration on the ordinate against the human IL-6 concentration on the abscissa. Draw a best fit curve through the points of the graph (a 5-parameter curve fit is recommended).
- To determine the concentration of circulating human IL-6 for each sample, first find the mean absorbance value on the ordinate and extend a horizontal line to the standard curve. At the point of intersection, extend a vertical line to the abscissa and read the corresponding human IL-6 concentration.
- **If instructions in this protocol have been followed samples have been diluted 1:2 (50 µL sample + 50 µL Assay Buffer (1x)) and the concentration read from the standard curve must be multiplied by the dilution factor (x 2).**
- **Calculation of samples with a concentration exceeding standard 1 may result in incorrect, low human IL-6 levels. Such samples require further external predilution according to expected human IL-6 values with Assay Buffer (1x) in order to precisely quantitate the actual human IL-6 levels.**
- It is suggested that each testing facility establishes a control sample of known human IL-6 concentration and runs this additional control with each assay. If the values obtained are not within the expected range of the control, the assay results may be invalid.
- A representative standard curve is shown in Figure 3. This curve cannot be used to derive test results. Each laboratory must prepare a standard curve for each group of microwell strips assayed.

Figure 3

Representative standard curve for Interleukin 6 (human) ELISA. Human IL-6 was diluted in serial 2-fold steps in Assay Buffer (1x). Do not use this standard curve to derive test results. A standard curve must be run for each group of microwell strips assayed.

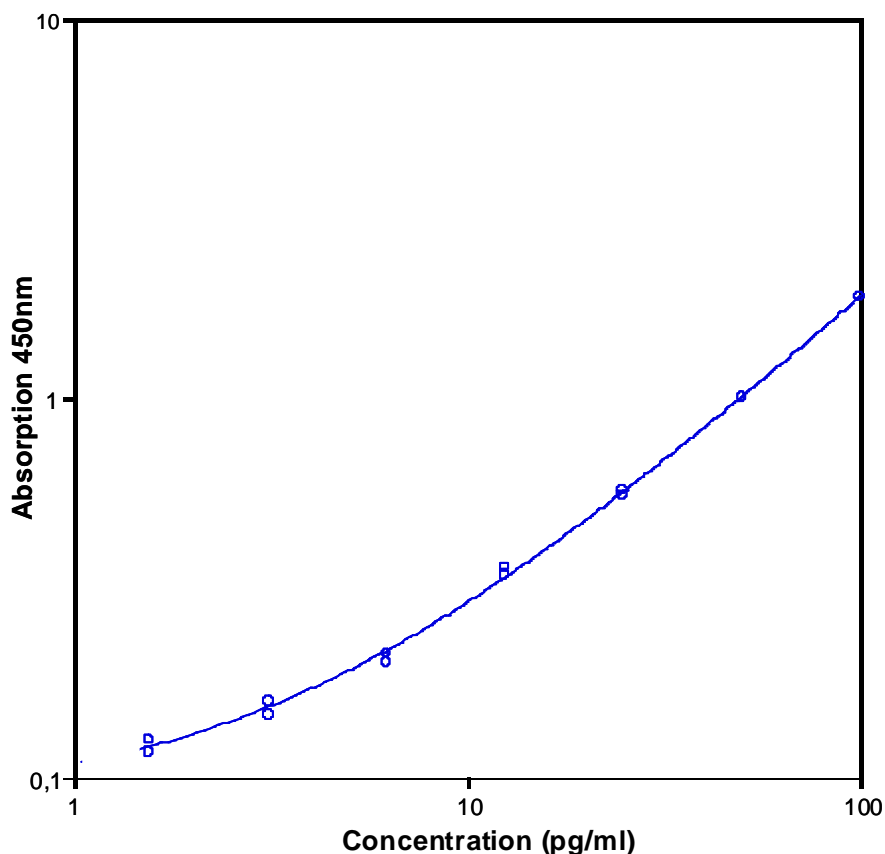

Table 2

Typical data using the Interleukin 6 (human) ELISA

Measuring wavelength: 450 nm, Reference wavelength: 620 nm

Standard	Human IL-6 Concentration (pg/mL)	O.D. (450 nm)	O.D. Mean	C.V. (%)
1	100.00	1.848 1.854	1.851	0.2
2	50.00	1.005 1.002	1.004	0.2
3	25.00	0.553 0.570	0.562	2.1
4	12.50	0.355 0.343	0.349	2.4
5	6.25	0.201 0.212	0.207	3.8
6	3.13	0.146 0.158	0.152	5.6
7	1.56	0.116 0.125	0.121	5.3
Blank	0.00	0.075 0.086	0.081	

The OD values of the standard curve may vary according to the conditions of assay performance (e.g. operator, pipetting technique, washing technique or temperature effects). Furthermore shelf life of the kit may affect enzymatic activity and thus colour intensity. Values measured are still valid.

12 LIMITATIONS

- Since exact conditions may vary from assay to assay, a standard curve must be established for every run.
- Bacterial or fungal contamination of either screen samples or reagents or cross-contamination between reagents may cause erroneous results.
- Disposable pipette tips, flasks or glassware are preferred, reusable glassware must be washed and thoroughly rinsed of all detergents before use.
- Improper or insufficient washing at any stage of the procedure will result in either false positive or false negative results. Empty wells completely before dispensing fresh wash solution, fill with Wash Buffer as indicated for each wash cycle and do not allow wells to sit uncovered or dry for extended periods.
- The use of radioimmunotherapy has significantly increased the number of patients with human anti-mouse IgG antibodies (HAMA). HAMA may interfere with assays utilizing murine monoclonal antibodies leading to both false positive and false negative results. Serum samples containing antibodies to murine immunoglobulins can still be analysed in such assays when murine immunoglobulins (serum, ascitic fluid, or monoclonal antibodies of irrelevant specificity) are added to the sample.

13 PERFORMANCE CHARACTERISTICS

13.1 Sensitivity

The limit of detection of human IL-6 defined as the analyte concentration resulting in an absorbance significantly higher than that of the dilution medium (mean plus 2 standard deviations) was determined to be 0.92 pg/mL (mean of 6 independent assays).

13.2 Reproducibility

13.2.1 Intra-assay

Reproducibility within the assay was evaluated in 2 independent experiments. Each assay was carried out with 6 replicates of 8 serum samples containing different concentrations of human IL-6. 2 standard curves were run on each plate. Data below show the mean human IL-6 concentration and the coefficient of variation for each sample (see Table 3). The calculated overall intra-assay coefficient of variation was 3.4%.

Table 3: The mean human IL-6 concentration and the coefficient of variation for each sample

Sample	Experiment	Mean Human IL-6 Concentration (pg/mL)	Coefficient of Variation (%)
1	1	40.7	7.8
	2	42.2	1.6
2	1	40.1	4.1
	2	40.1	2.6
3	1	43.2	1.1
	2	41.7	3.5
4	1	65.6	2.3
	2	65.4	4.6
5	1	47.2	1.6
	2	48.0	2.1
6	1	34.1	2.5
	2	37.8	5.4
7	1	27.3	0.2
	2	35.2	7.7
8	1	37.8	4.1
	2	42.6	2.4

13.2.2 Inter-assay

Assay to assay reproducibility within one laboratory was evaluated in 2 independent experiments. Each assay was carried out with 6 replicates of 8 serum samples containing different concentrations of human IL-6. 2 standard curves were run on each plate. Data below show the mean human IL-6 concentration and the coefficient of variation calculated on 18 determinations of each sample (see Table 4). The calculated overall inter-assay coefficient of variation was 5.2%.

Table 4: The mean human IL-6 concentration and the coefficient of variation of each sample

Sample	Mean Human IL-6 Concentration (pg/mL)	Coefficient of Variation (%)
1	41.5	2.6
2	40.1	0.0
3	42.5	4.4
4	65.5	0.2
5	47.6	1.2
6	35.9	7.3
7	31.3	17.8
8	40.2	8.4

13.3 Spike Recovery

The spike recovery was evaluated by spiking 4 levels of human IL-6 into serum. Recoveries were determined in 2 independent experiments with 8 replicates each. The unspiked serum was used as blank in these experiments. The recovery ranged from 78% to 105% with an overall mean recovery of 88%.

13.4 Dilution Parallelism

Serum samples with different levels of human IL-6 were analysed at serial 2 fold dilutions with 4 replicates each. The recovery ranged from 98% to 111% with an overall recovery of 105% (see Table 5).

Table 5

Sample	Dilution	Expected Human IL-6 Concentration (pg/mL)	Observed Human IL-6 Concentration (pg/mL)	Recovery of Expected Concentration (%)
1	1:2	-	46.4	-
	1:4	23.2	22.7	98
	1:8	11.6	11.8	102
2	1:2	-	95.0	-
	1:4	47.5	50.3	106
	1:8	23.8	23.4	99
3	1:2	-	51.9	-
	1:4	26.0	28.8	111
	1:8	13.0	14.4	111

13.5 Sample Stability

13.5.1 Freeze-Thaw Stability

Aliquots of serum samples (unspiked or spiked) were stored at -20 °C and thawed 5 times, and the human IL-6 levels determined. There was no significant loss of human IL-6 immunoreactivity detected by freezing and thawing.

13.5.2 Storage Stability

Aliquots of serum samples (spiked or unspiked) were stored at -20 °C, 2 °C - 8 °C, room temperature (RT) and at 37 °C, and the human IL-6 level determined after 24 h. There was no significant loss of human IL-6 immunoreactivity detected during storage under above conditions.

13.6 Comparison of Serum and Plasma

From two individuals, serum as well as EDTA, citrate and heparin plasma obtained at the same time point were evaluated. Human IL-6 concentrations were not significantly different and therefore all these body fluids are suitable for the assay. It is nevertheless highly recommended to assure the uniformity of blood preparations.

13.7 Specificity

The interference of circulating factors of the immune system was evaluated by spiking these proteins at physiologically relevant concentrations into a human IL-6 positive serum. There was no cross reactivity detected.

13.8 Expected Values

A panel of samples from randomly selected apparently healthy donors (males and females) was tested for human IL-6. The levels measured may vary with the sample collection used. For detected human IL-6 levels see Table 6.

Table 6

Sample Matrix	Number of Samples Evaluated	Range (pg/mL)	% Detectable	Mean of Detectable (pg/mL)
Serum	40	nd *- 12.7	47.5	5.8
Plasma (EDTA)	40	nd *- 13.0	17.5	6.4
Plasma (Citrate)	40	nd *- 6.6	2.5	6.6
Plasma (Heparin)	40	nd *- 6.5	30.0	5.0

* n.d. = non-detectable, samples measured below the lowest standard point are considered to be non-detectable.

13.9 Calibration

The immunoassay is calibrated with highly purified recombinant human IL-6 which has been evaluated against the international Reference Standard NIBSC 89/548 and has been shown to be equivalent.

NIBSC 89/548 is quantitated in International Units (IU), 1IU corresponding to 10 pg human IL-6.

14 REAGENT PREPARATION SUMMARY**14.1 Wash Buffer (1x)**

Add **Wash Buffer Concentrate** 20x (50 mL) to 950 mL distilled water.

Number of Strips	Wash Buffer Concentrate (mL)	Distilled Water (mL)
1 - 6	25	475
1 - 12	50	950

14.2 Assay Buffer (1x)

Add **Assay Buffer Concentrate** 20x (5 mL) to 95 mL distilled water.

Number of Strips	Assay Buffer Concentrate (mL)	Distilled Water (mL)
1 - 6	2.5	47.5
1 - 12	5.0	95.0

14.3 Biotin-Conjugate

Make a 1:100 dilution of **Biotin-conjugate** in Assay Buffer (1x):

Number of Strips	Biotin-Conjugate (mL)	Assay Buffer (1x) (mL)
1 - 6	0.03	2.97
1 - 12	0.06	5.94

14.4 Streptavidin-HRP

Make a 1:200 dilution of **Streptavidin-HRP** in Assay Buffer (1x):

Number of Strips	Streptavidin-HRP (mL)	Assay Buffer (1x) (mL)
1 - 6	0.03	5.97
1 - 12	0.06	11.94

14.5 Human IL-6 Standard

Reconstitute lyophilized **human IL-6 standard** with distilled water. (Reconstitution volume is stated on the label of the standard vial.)

14.6 Controls

Add 300 µL distilled water to lyophilized **controls**.

15 TEST PROTOCOL SUMMARY

1. Determine the number of microwell strips required.
2. Wash microwell strips twice with Wash Buffer.
3. Standard dilution on the microwell plate: Add 100 µL Assay Buffer (1x), in duplicate, to all standard wells. Pipette 100 µL prepared standard into the first wells and create standard dilutions by transferring 100 µL from well to well. Discard 100 µL from the last wells.
Alternatively external standard dilution in tubes (see 9.5.1: Pipette 100 µL of these standard dilutions in the microwells.
4. Add 100 µL Assay Buffer (1x), in duplicate, to the blank wells.
5. Add 50 µL Assay Buffer (1x) to sample wells.
6. Add 50 µL sample in duplicate, to designated sample wells.
7. Prepare Biotin-Conjugate.
8. Add 50 µL Biotin-Conjugate to all wells.
9. Cover microwell strips and incubate 2 hours at room temperature (18 °C to 25 °C).
10. Prepare Streptavidin-HRP.
11. Empty and wash microwell strips 4 times with Wash Buffer.
12. Add 100 µL diluted Streptavidin-HRP to all wells.
13. Cover microwell strips and incubate 1 hour at room temperature (18 °C to 25 °C).
14. Empty and wash microwell strips 4 times with Wash Buffer.
15. Add 100 µL of TMB Substrate Solution to all wells.
16. Incubate the microwell strips for about 10 minutes at room temperature (18 °C to 25 °C).
17. Add 100 µL Stop Solution to all wells.
18. Blank microwell reader and measure colour intensity at 450 nm.

Note: If instructions in this protocol have been followed samples have been diluted 1:2 (50 µL sample + 50 µL Assay (1x)) and the concentration read from the standard curve must be multiplied by the dilution factor (x 2).

1 MITGELIEFERTE REAGENZIEN

Mitgelieferte Reagenzien für Interleukin 6 (human) ELISA (96 Tests)

- 1 Aluminiumbeutel mit **Mikrotiterplatte, beschichtet** mit Antikörper (monoklonal) gegen human IL-6
- 1 Fläschchen (70 µL) **Biotin-Konjugat**, monoklonaler anti-human IL-6 Antikörper
- 1 Fläschchen (150 µL) **Streptavidin-HRP**
- 2 Fläschchen human IL-6-**Standard**, lyophilisiert, 200 pg/mL nach Rekonstitution
- 1 Fläschchen lyophilisierte **Kontrolle, hoch konzentriert**
- 1 Fläschchen lyophilisierte **Kontrolle, niedrig konzentriert**
- 1 Fläschchen (5 mL) **Probenpufferkonzentrat 20x**
(PBS mit 1% Tween 20, 10% BSA)
- 1 Flasche (50 mL) **Waschpufferkonzentrat 20x**
(PBS mit 1% Tween 20)
- 1 Fläschchen (15 mL) **Substratlösung** (Tetramethylbenzidin)
- 1 Fläschchen (15 mL) **Stopplösung** (1 M Phosphorsäure)
- 4 **Klebefolien**

2 LAGERHINWEISE

Lagern Sie den Inhalt des Kits mit Ausnahme der Kontrollen bei 2 °C - 8 °C.

Lagerung der lyophilisierten Kontrollen bei -20 °C .

Verbliebene Reagenzien nach Verwendung sofort wieder auf 2 °C - 8 °C, bzw. auf -20 °C kühlen. Das Ablaufdatum des Kits und der Reagenzien ist auf den Etiketten angegeben.

Die Haltbarkeit des Kits und der Komponenten kann nur bei fachgerechter Lagerung garantiert werden, sowie bei mehrfacher Verwendung nur dann, wenn die Reagenzien bei der ersten Verwendung nicht kontaminiert wurden.

3 SICHERHEITSVORKEHRUNGEN FÜR DEN GEBRAUCH

- Alle enthaltenen Reagenzien sollten als potenziell gefährlich betrachtet werden. Daher wird empfohlen, dass dieses Produkt nur von Personen mit labortechnischer Erfahrung und in Übereinstimmung mit GLP Richtlinien verwendet wird. Passende Schutzbekleidung, wie Labormäntel, Sicherheitsbrillen und Laborhandschuhe müssen getragen werden. Vermeiden Sie jeden Kontakt der Reagenzien mit Haut oder Augen. Im Falle des Kontaktes von Reagenzien mit Haut oder Augen, sofort mit Wasser spülen. Bitte entnehmen Sie weitere spezifische Hinweise den Sicherheitsdatenblättern und/oder den Sicherheitsbestimmungen.
- Die Reagenzien sind **ausschließlich für Forschungszwecke** bestimmt und nicht für den Einsatz in Diagnostik oder bei Therapien
- Reagenzien aus verschiedenen Chargen oder anderer Herkunft nicht mischen oder untereinander austauschen.
- Verwenden Sie die Kitreagenzien nicht nach dem Ablaufdatum (siehe Etikett).
- Setzen Sie die Kitreagenzien während der Lagerung oder Inkubation keiner starken Lichteinstrahlung aus.
- Nicht mit dem Mund pipettieren.
- In Bereichen, in denen mit Kitreagenzien oder Proben hantiert wird, nicht essen, trinken oder rauchen.
- Vermeiden Sie den Kontakt der Haut/Schleimhäute mit Kitreagenzien/Proben.
- Tragen Sie während des Hantierens mit Kitreagenzien oder Proben geeignete Gummi- oder Einweghandschuhe.
- Vermeiden Sie den Kontakt zwischen Substratlösung und Oxidationsmitteln/Metallen.
- Vermeiden Sie Verspritzen von Flüssigkeit oder Bildung von Aerosolen.
- Zur Vermeidung von Kontamination mit Mikroben oder Kreuzkontamination der Reagenzien oder Proben, die den Test ungültig machen könnten, verwenden Sie Einwegpipettenspitzen und/oder Einwegpipetten.
- Verwenden Sie saubere, geeignete Reagenzgefäße für das Dispensieren von Konjugat und Substratreagenzien.
- Vermeiden Sie Kontakt mit Säuren, da dadurch Konjugate inaktiviert werden.
- Für die Reagenzherstellung muss destilliertes oder entionisiertes Wasser verwendet werden.
- Die Substratlösung muss vor der Verwendung auf Raumtemperatur gebracht werden.
- Dekontaminieren und entsorgen Sie Proben sowie alle möglicherweise kontaminierten Materialien so, als ob sie Infektionserreger enthalten könnten. Die bevorzugte Dekontaminationsmethode ist Autoklavieren für mind. eine Stunde bei 121,5 °C.

- Flüssige Abfälle, die kein Säure enthalten, sowie neutralisierte Abfälle werden zur Dekontamination mit Natrium Hypochlorit versetzt (Endkonzentration von Natrium Hypochlorit 1.0%). Nach 30 min ist eine effektive Dekontamination erreicht. Flüssige Abfälle, die Säure enthalten, müssen vor der Dekontamination neutralisiert werden.

4 VORBEREITUNG DER REAGENZIEN

Bringen Sie die **Pufferkonzentrate** auf Raumtemperatur und stellen Sie die Verdünnungen vor Beginn des Tests her. Sollten sich in den **Pufferkonzentraten** Kristalle gebildet haben, erwärmen Sie diese vorsichtig bis zur vollständigen Auflösung der Kristalle.

4.1 Waschpuffer (1x)

Leeren Sie den gesamten Inhalt (50 mL) des **Waschpufferkonzentrats** (20x) in einen sauberen 1000-ml-Messzylinder. Füllen Sie mit destilliertem oder entionisiertem Wasser auf, bis ein Endvolumen von 1000 mL erreicht ist. Mischen Sie vorsichtig um Schäumen zu vermeiden.

Füllen Sie in eine saubere Waschflasche um und lagern Sie den Waschpuffer (1x) bei 2 °C bis 25 °C lagern. Bitte beachten Sie, dass dieser 30 Tage haltbar ist.

Der benötigte Waschpuffer (1x) kann auch entsprechend der untenstehenden Tabelle hergestellt werden:

Anzahl der Streifen	Waschpufferkonzentrat (20x) (mL)	Destilliertes Wasser (mL)
1 - 6	25	475
1 - 12	50	950

4.2 Probenpuffer (1x)

Leeren Sie den gesamten Inhalt (5 mL) des **Probenpufferkonzentrates** (20x) in einen sauberen 100-ml-Messzylinder. Füllen Sie mit destilliertem oder entionisiertem Wasser auf, bis ein Endvolumen von 100 mL erreicht ist. Mischen Sie vorsichtig um Schäumen zu vermeiden.

Probenpuffer (1x) bei 2 °C bis 8 °C lagern. Bitte beachten Sie, dass der Probenpuffer (1x) 30 Tage haltbar ist.

Der benötigte Probenpuffer (1x) kann auch entsprechend der untenstehenden Tabelle hergestellt werden:

Anzahl der Streifen	Probenpufferkonzentrat (20x) (mL)	Destilliertes Wasser (mL)
1 - 6	2.5	47.5
1 - 12	5.0	95.0

4.3 Biotin-Konjugat

Bitte beachten Sie, dass die Biotin-Konjugatlösung nach der Verdünnung nur 30 Minuten haltbar ist.

Stellen Sie eine 1:100 Verdünnung der konzentrierten **Biotin-Konjugatlösung** in Probenpuffer (1x) in einem sauberen Gefäß entsprechend der untenstehenden Tabelle her.

Anzahl der Streifen	Biotin-Konjugat (mL)	Probenpuffer (1x) (mL)
1 - 6	0.03	2.97
1 - 12	0.06	5.94

4.4 Streptavidin-HRP

Bitte beachten Sie, dass die Streptavidin-HRP-Lösung nach der Verdünnung nur 30 Minuten haltbar ist.

Stellen Sie eine 1:200 Verdünnung der konzentrierten **Streptavidin-HRP-Lösung** in Probenpuffer (1x) in einem sauberen Gefäß entsprechend der untenstehenden Tabelle her.

Anzahl der Streifen	Streptavidin-HRP (mL)	Probenpuffer (1x) (mL)
1 - 6	0.03	5.97
1 - 12	0.06	11.94

4.5 Human IL-6-Standard

Rekonstituieren Sie den **human IL-6 -Standard** durch Zugabe von destilliertem Wasser. Das Rekonstitutionsvolumen ist auf dem Standardfläschchen angegeben. Rühren oder mischen Sie vorsichtig um eine vollständige und homogene Auflösung zu erzielen (Konzentration des rekonstituierten Standards = 200 pg/mL).

Den rekonstituierten Standard nach 10-30 min verdünnen und davor gut mischen.

Der Standard muss sofort nach Rekonstitution verwendet und kann nicht gelagert werden.

Die **Standardverdünnungen** können direkt auf den Mikrotiterplatten (siehe 5.c) oder in Reaktionsgefäßen (siehe 4.5.1) hergestellt werden.

4.5.1 Externe Standardverdünnung

Beschriften Sie 7 Gefäße, jedes für einen Standardpunkt wie folgt:

S1, S2, S3, S4, S5, S6, S7

Stellen Sie eine 1:2 Verdünnungsreihe für die Standardkurve her:

Pipettieren Sie in jedes Gefäß 225 µL der Probenpuffer (1x).

Pipettieren Sie 225 µL des rekonstituierten Standards (Konzentration des Standards = 200 pg/mL) in das erste Gefäß mit der Beschriftung S1 und mischen Sie (Konzentration des Standard 1 = 100 pg/mL).

Pipettieren Sie 225 µL dieser Verdünnung in das zweite Gefäß (mit der Beschriftung S2) und mischen Sie sorgfältig vor dem nächsten Verdünnungsschritt.

Wiederholen Sie diese Verdünnungsschritte 5x. Die so hergestellte Verdünnungsreihe dient zur Erstellung der Standardkurve (siehe Abbildung 1).

Probenpuffer (1x) dient als Blindwert.

Abbildung 1

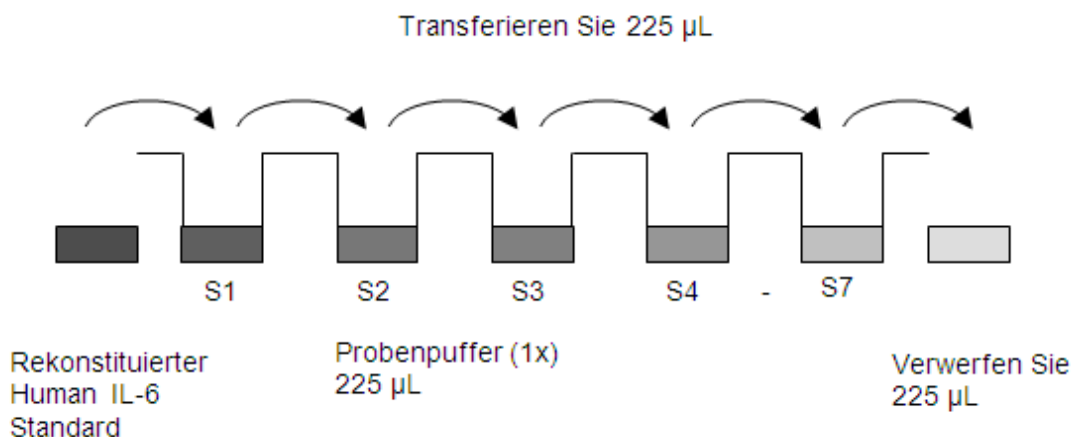

4.6 Kontrollen

Lösen Sie die **Kontrollen** durch Zugabe von 300 µL destilliertem Wasser auf. Für die Kontrollen 10-30 min Rekonstitutionszeit einhalten. Mixen oder schütteln Sie die Fläschchen vorsichtig um eine vollständige Lösung zu erreichen. Verfahren Sie in der Folge mit den Kontrollen analog zu den Proben. Der Konzentrationsbereich der Kontrollen ist am Analysenzertifikat oder am Flaschenetikett angegeben.

Lagern sie die rekonstituierten Kontrollen aliquotiert bei -20 °C. Vermeiden Sie wiederholtes Frieren und Tauen.

5 TESTPROTOKOLL

- a. Bestimmen Sie die Anzahl der Mikrowellstreifen die für das Testen der gewünschten Anzahl von Proben benötigt werden, sowie die Mikrowellstreifen für Blindwert und Standards. Probe, Standard, Blindwert immer jeweils doppelt testen. Entfernen Sie die zusätzlichen Mikrowellstreifen von der Halterung und bewahren Sie diese mit dem mitgelieferten Trockenmittel in dem Folienbeutel fest verschlossen bei 2 °C - 8 °C auf.
- b. Waschen Sie die Mikrowellstreifen 2-mal mit ca. 400 µL **Waschpuffer** pro Vertiefung; zwischen den Waschgängen den Inhalt der Vertiefungen gründlich absaugen. Vor dem Absaugen Waschpuffer **10 - 15 Sekunden** einwirken lassen. Achten Sie darauf, die Oberfläche der Vertiefungen nicht zu zerkratzen. Leeren Sie die Vertiefungen nach dem letzten Waschschrift und klopfen Sie die Mikrowellstreifen auf einem Saug- oder Papiertuch aus um überschüssigen Waschpuffer zu entfernen. Verwenden Sie die Mikrowellstreifen sofort nach dem Waschen, oder legen Sie diese für maximal 15 min umgedreht auf ein nasses Saugtuch. **Lassen Sie die Vertiefungen nicht austrocknen.**
- c. **Standardverdünnung auf der Mikrotiterplatte** (Wahlweise können die Standardverdünnungen auch in Reaktionsgefäßen hergestellt werden – siehe 4.5.1)
 Pipettieren Sie 100 µL Probenpuffer (1x) in alle **Standardvertiefungen**. Pipettieren Sie 100 µL des rekonstituierten **Standards** (siehe Herstellung des Standards, Konzentration des Standards = 200 pg/mL) in die Vertiefungen A1 und A2 (Doppelbestimmung, siehe Tabelle 1). Mischen Sie den Inhalt der Vertiefungen A1 und A2 durch wiederholtes Aufsaugen und Zugeben gut durch (Konzentration des Standards S1 = 100 pg/mL) und transferieren Sie 100 µL in die Probenvertiefungen B1 und B2 (siehe Abbildung 2). Achten Sie darauf, die Oberfläche der Vertiefungen nicht zu zerkratzen. Wiederholen Sie diese Verdünnungsschritte 5x, wodurch zwei human IL-6 Verdünnungsreihen mit den Konzentrationen von 100 bis 1.56 pg/mL hergestellt werden. Verwerfen Sie 100 µL aus den letzten Standardvertiefungen (G1/2). Die so hergestellten Verdünnungsreihen dienen zur Erstellung der Standardkurve.

Abbildung 2

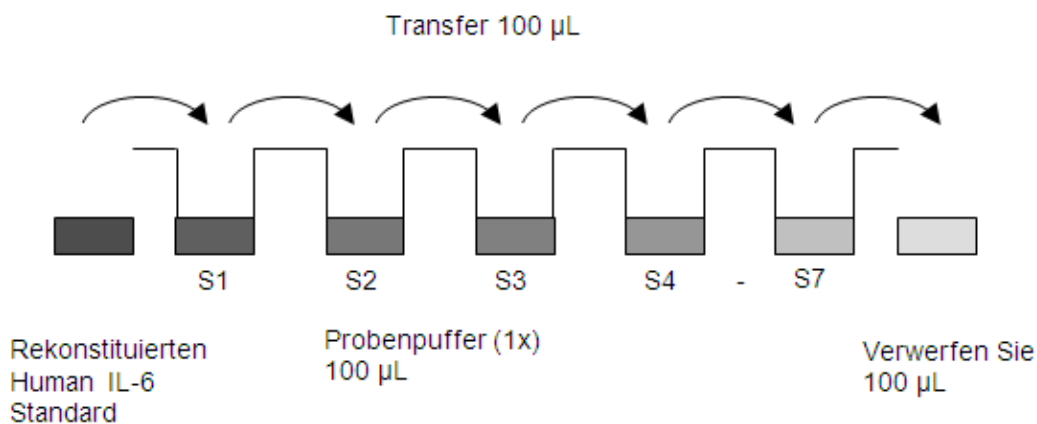

Falls sie eine **externe Standardverdünnungsreihe** erstellen (siehe 4.5.1), pipettieren Sie 100 µL der Standardverdünnungen (S1 – S7) in die Standardvertiefungen (entsprechend Tabelle 1).

Tabelle 1

Diagramm mit Beispiel für die Anordnung von Blindwert, Standards und Proben in den Mikrowellstreifen:

	1	2	3	4
A	Standard 1 (100.00 pg/mL)	Standard 1 (100.00 pg/mL)	Probe 1	Probe 1
B	Standard 2 (50.00 pg/mL)	Standard 2 (50.00 pg/mL)	Probe 2	Probe 2
C	Standard 3 (25.00 pg/mL)	Standard 3 (25.00 pg/mL)	Probe 3	Probe 3
D	Standard 4 (12.50 pg/mL)	Standard 4 (12.50 pg/mL)	Probe 4	Probe 4
E	Standard 5 (6.25 pg/mL)	Standard 5 (6.25 pg/mL)	Probe 5	Probe 5
F	Standard 6 (3.13 pg/mL)	Standard 6 (3.13 pg/mL)	Probe 6	Probe 6
G	Standard 7 (1.56 pg/mL)	Standard 7 (1.56 pg/mL)	Probe 7	Probe 7
H	Blindwert	Blindwert	Probe 8	Probe 8

- d. Pipettieren Sie in alle **Blindwertvertiefungen** (Doppelbestimmung), 100 µL **Probenpuffer (1x)**.
- e. Pipettieren Sie in alle **Probenvertiefungen** 50 µL **Probenpuffer (1x)**.
- f. Pipettieren Sie je 50 µL von jeder **Probe** (Doppelbestimmung) in die **Probenvertiefungen** und mischen Sie den Inhalt durch.
- g. Stellen Sie **Biotin-Konjugat** (siehe: Vorbereitung der Reagenzien Biotin-Konjugat 4.3) her.
- h. Pipettieren Sie in alle Vertiefungen, einschließlich der Blindwertvertiefungen 50 µL **Biotin-Konjugat**.
- i. Mit einer Klebefolie abdecken und bei Raumtemperatur (18 °C bis 25 °C) für 2 Stunden inkubieren, wenn möglich auf einem Schüttler bei 400 rpm.
- j. Stellen Sie **Streptavidin-HRP** (siehe: Vorbereitung der Reagenzien Streptavidin-HRP 4.4) her.
- k. Entfernen Sie die Klebefolie und leeren Sie die Vertiefungen. **Waschen** Sie die Mikrowellstreifen 4-mal wie in Punkt b. dem Testprotokoll beschrieben. Verwenden Sie die Mikrowellstreifen sofort nach dem Waschen.
- l. Pipettieren Sie in alle Vertiefungen, einschließlich der Blindwertvertiefungen 100 µL **Streptavidin-HRP**.
- m. Mit einer Klebefolie abdecken und bei Raumtemperatur (18 °C bis 25 °C) für 1 Stunde inkubieren, wenn möglich auf einem Schüttler bei 400 rpm.
- n. Entfernen Sie die Klebefolie und entleeren Sie die Vertiefungen. **Waschen** Sie die Mikrowellstreifen 4-mal wie in Punkt b des Testprotokolls beschrieben. Verwenden Sie die Mikrowellstreifen sofort nach dem Waschen.
- o. Pipettieren Sie in alle Vertiefungen, einschließlich der Blindwertvertiefungen, 100 µL **TMB-Substratlösung**.
- p. Inkubieren Sie die Mikrowellstreifen bei Raumtemperatur (18 °C bis 25 °C) für ca. 10 Minuten. Vermeiden Sie direkte, starke Lichteinstrahlung.

Die Farbentwicklung innerhalb der einzelnen Vertiefungen muss beobachtet und die Substratreaktion gestoppt werden (siehe nächster Protokollpunkt), bevor die gefärbten Vertiefungen nicht mehr richtig gemessen werden können.

Die optimale Inkubationszeit für die Farbentwicklung muss bei jedem Versuch neu bestimmt werden.

Es wird empfohlen, die **Stopplösung** zuzugeben, wenn der höchste Standardpunkt eine dunkelblaue Farbe angenommen hat.

Alternativ kann die Farbentwicklung auch mit einem Photometer bei 620 nm verfolgt werden. Die Substratreaktion sollte gestoppt werden, wenn der höchste Standardpunkt eine OD von 0.9 -0.95 erreicht.

- q. Stoppen Sie die Enzymreaktion durch rasche Zugabe von 100 µL Stopplösung in jede Vertiefung, einschließlich der Blindwertvertiefungen. Für eine vollständige Inaktivierung der Enzyme ist es wichtig, die Stopplösung rasch und gleichmäßig in den Vertiefungen zu verteilen. Die OD Werte müssen sofort nach Zugabe der Stopplösung oder innerhalb einer Stunde nach Lagerung der Mikrowellstreifen in Dunkelheit bei 2-8 °C gemessen werden.
- r. Messen Sie die Absorption jeder Vertiefung mit einem Spektrophotometer. Verwenden Sie dabei 450 nm als primäre Wellenlänge (optional 620 nm als Referenzwellenlänge; 610 nm bis 650 nm sind möglich). Stellen Sie das Plattenmessgerät nach Anleitung des Herstellers und unter Verwendung der Blindwertvertiefungen auf den Leerwert ein. Bestimmen Sie die Absorption der Proben wie auch der human IL-6-Standards.

Die Proben wurden im Zuge der Testdurchführung 1:2 verdünnt. Daher muss der aus der Standardkurve berechnete Wert mit dem Verdünnungsfaktor multipliziert werden (x 2).

Anmerkung:

Falls die Platte während der Inkubation nicht geschüttelt wurde, können die erreichten OD Werte niedriger als die unten angeführten sein. Die Ergebnisse sind trotzdem gültig.

SYMBOLS USED

Symbol	English	Deutsch	Italiano	Español	Français
	European Conformity	CE-Konformitäts-kennzeichnung	Conformità europea	Conformidad europea	Conformité normes européennes
	Consult instructions for use *	Gebrauchsanweisung beachten *	Consultare le istruzioni per l'uso	Consulte las instrucciones de uso	Consulter les instructions d'utilisation
	<i>In vitro</i> diagnostic medical device *	<i>In-vitro</i> -Diagnostikum *	Dispositivo medico-diagnostico in vitro	Producto sanitario para diagnóstico In vitro	Dispositif médical de diagnostic in vitro
	Catalogue number *	Artikelnummer *	Numero di Catalogo	Número de catálogo	Référence de catalogue
	Batch code *	Chargencode *	Codice del lotto	Codigo de lote	Numéro de lot
	Contains sufficient for <n> tests *	Ausreichend für <n> Prüfungen *	Contenuto sufficiente per "n" saggi	Contenido suficiente para <n> ensayos	Contenu suffisant pour "n" tests
	Temperature limit *	Temperaturbegrenzung *	Temperatura di conservazione	Temperatura de conservación	Température de conservation
	Use-by date *	Verwendbar bis *	Utilizzare prima del	Establa hasta	Utiliser jusque
	Manufacturer *	Hersteller *	Fabbricante	Fabricante	Fabricant
	Caution *	Achtung *			
	For research use only	Nur für Forschungszwecke	Solo a scopo di ricerca	Sólo para uso en investigación	Seulement dans le cadre de recherches
<i>Distributed by</i>	Distributed by	Vertreiber	Distributore	Distribuidor	Distributeur
<i>Content</i>	Content	Inhalt	Contenuto	Contenido	Contenu
<i>Volume/No.</i>	Volume / No.	Volumen/Anzahl	Volume/Quantità	Volumen/Número	Volume/Quantité